

# SHOWCASES | Ice Cream

ICE CREAM SCOPING CABINETS

# VBG 3B

**CUSTOMIZATION AVAILABLE**  
PERSONALIZZAZIONE DISPONIBILE

	GAS <b>R290</b>	 60 mm	<b>B</b> ENERGY CLASS	<b>4</b> +30°C/55RH
50Hz 60Hz	 LED			

## DETAILS

Main switch, light switch and digital thermostat fitted as standard	Lights along the whole body frame	Hands-free access



## GENERAL FEATURES

- Ice cream countertop showcase
- Black coated steel for external and white internally
- Foaming Agent Cyclopentane (60mm)
- Static Cooling
- Manual Defrost
- Digital Thermostat
- Interior LED light
- Independent main and light switches
- Front-opening glass with assisted lift (hands-free access)
- Heated glass door with double safety tempered glass
- Black "frameless" door with Safety tempered glass
- 360x165x120mm Ice cream pans (5 Litres) capacity: 3 pcs
- Easy removable condenser filter
- N.4 Adjustable feet
- Energy efficiency class: B

## TECHNICAL SPECIFICATIONS

Capacity	<b>78 L</b>
Temperature	<b>-16° - -18°C</b>
Consumption	<b>3.2 kWh/24h</b>
Rated Power	<b>230 W</b>
Noise level	<b>43 dB(A)</b>
Net Weight	<b>35 Kg</b>
Gross Weight	<b>56 Kg</b>
External Dimensions (WxDxH mm)	<b>670x750x392</b>
Internal Dimensions (WxDxH mm)	<b>550x415x210</b>
Packaging dimensions (WxDxH mm)	<b>734x813x574</b>
Loading quantities 20'/40'/40'HQ	<b>84/168/168</b>

## PRODUCT DIMENSIONS

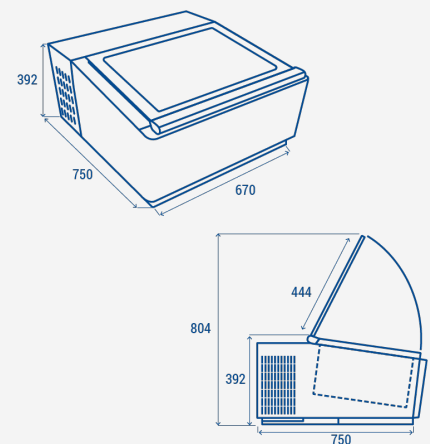

## CERTIFICATION

CE RoHS

